

Installation of door frames

Selection of frameworks for AQUAPANEL® Cement Board Indoor

The formation of the framework depends on the wall height, the door width and the weights of the door panels.

Maximum door weight

Profile	Weight
CW 50	≤ 30 kg
CW 75	≤ 40 kg
CW 100	≤ 40 kg
UA 50	≤ 50 kg
UA 75	≤ 75 kg
UA 100	≤ 100 kg

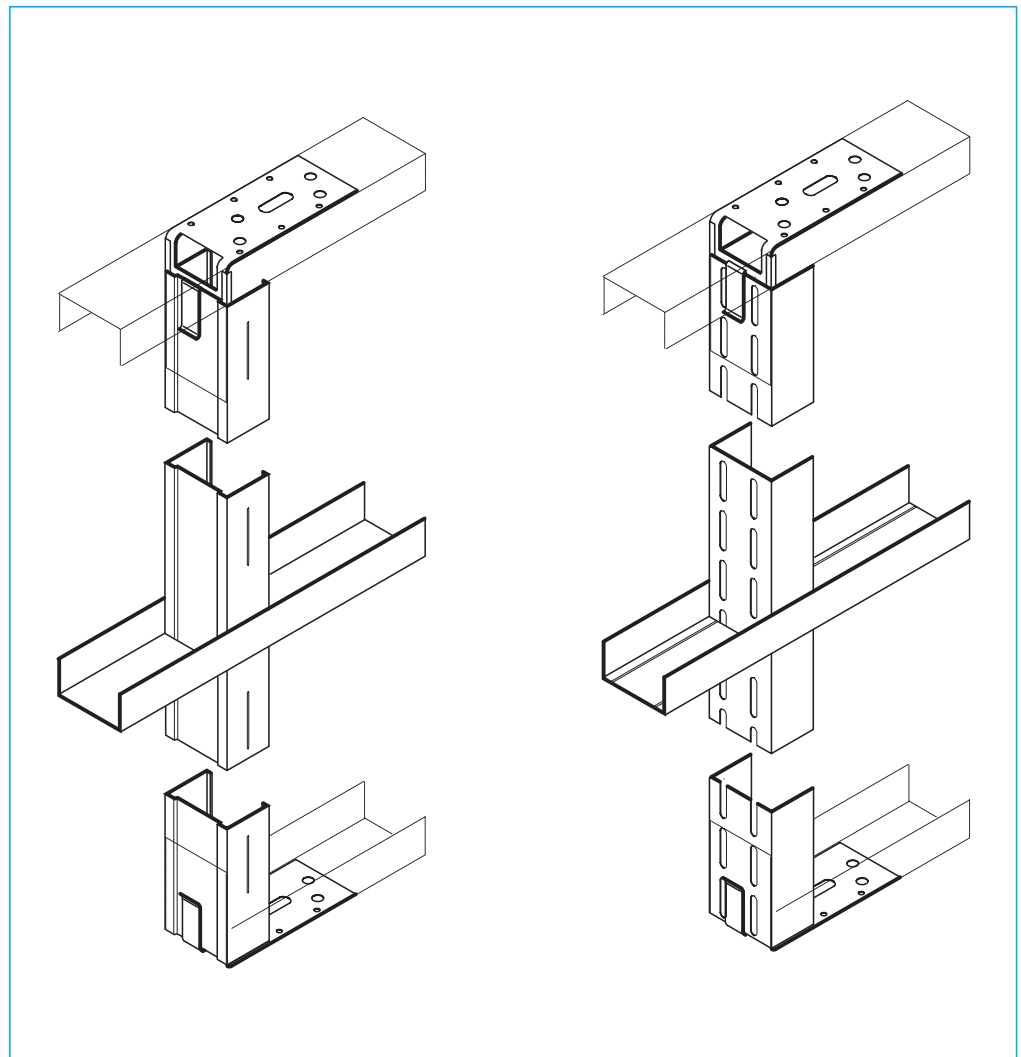

Variant CW-Profile

Variant UA-Profile

Profile	Overlap ü
CW / UA 50	≥ 50 cm
CW / UA 75	≥ 75 cm
CW / UA 100	≥ 100 cm

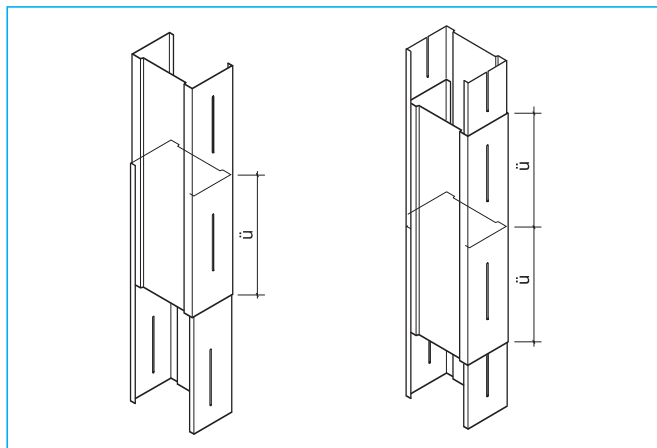

Extension of CW-profiles

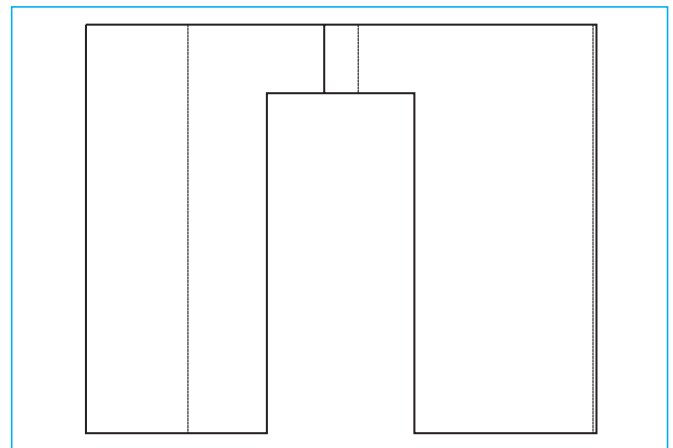

Construction of doorway

Details

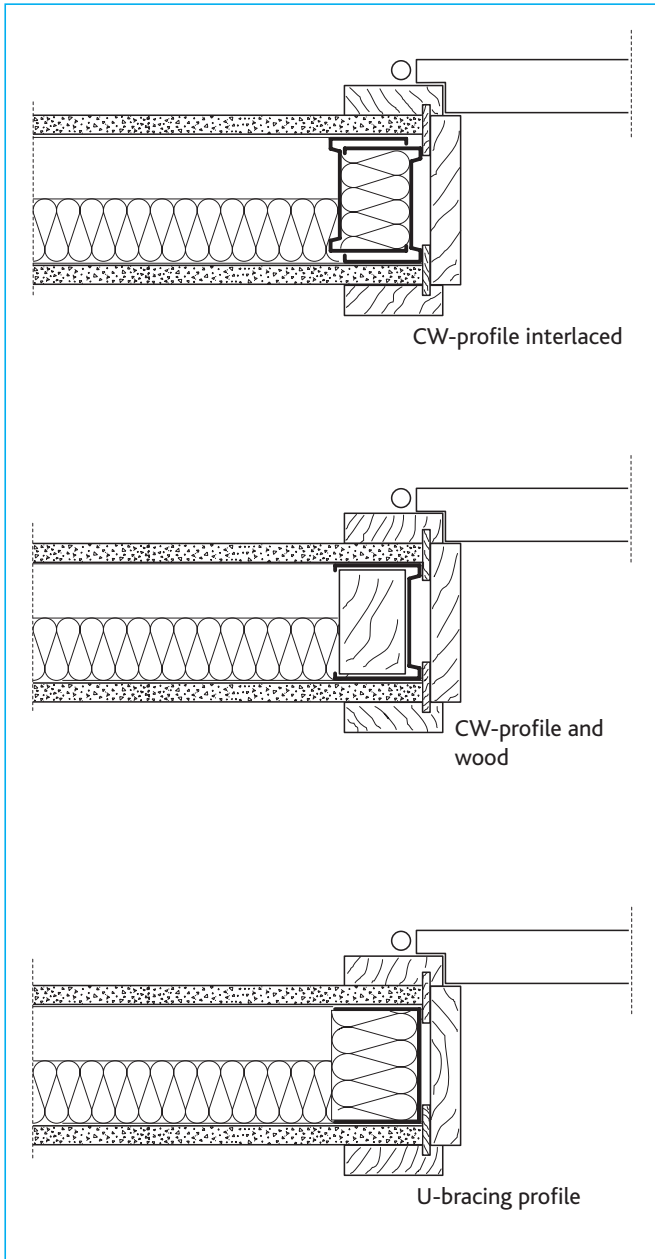

Inside door with wooden frame

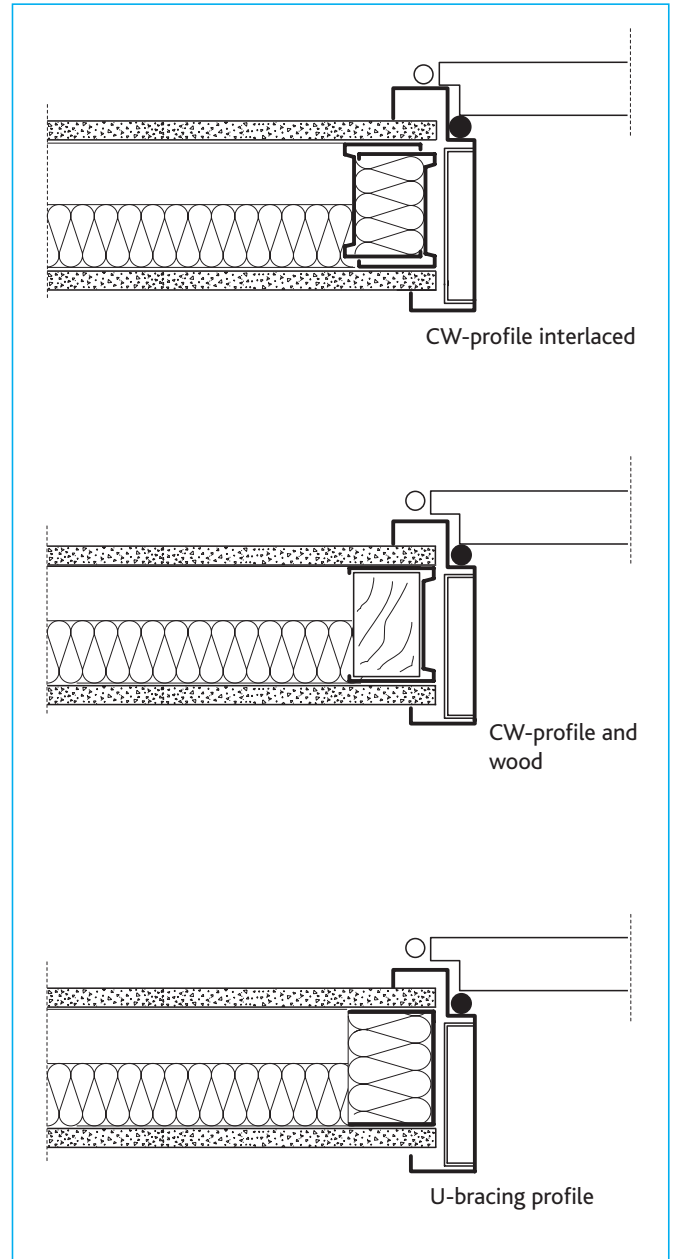

Inside door with metal frame

Maximum cut-outs in CW-profiles

As well as the standard H-punch, the following holes can be produced:

Metal stud frame	Layer	Number of holes
CW 50	2-sided	1 per profile
CW 75/100	1 side	1 per profile
	2-sided	2 per profile

