

The background of the page is a detailed cross-section diagram of a rainscreen facade system. On the left, a white textured panel is shown. To its right is a yellowish insulation layer with a blue grid pattern. Further right is a vertical metal profile, and to its right is a grey concrete wall. A metal bracket is shown connecting the profile to the wall. The diagram illustrates the airflow path through the rainscreen system.

WL132C.2

Rear-Ventilated Rainscreen Facade, Without Thermal Insulation



Fine sponged render



Pebble dash



WL132C.2

Rear-ventilated rainscreen facade, without thermal insulation

On projects where insulation is not required – typically during some purely cosmetic renovations – Knauf Exterior Wall can be used to create very thin rear-ventilated rainscreen facade constructions. In this WL132C.2 system the facade thickness in front of the existing massive wall is just 65 mm, making it the ideal solution in urban environments, where limited space is a crucial factor in the decision for a particular construction. Additionally the fast and easy installation and the low weight of the materials guarantee a low impact construction site, keeping the noise pollution and traffic interferences to a minimum.



Groove render

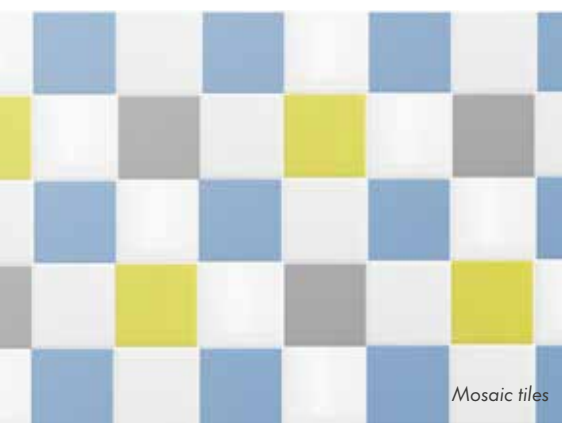

Mosaic tiles



CONTENTS

Axonometry	4
Construction drawings	5
Sample specifications	14
Product range	23
Product handling and installation	27
Material consumption and erection time	36

Axonometry

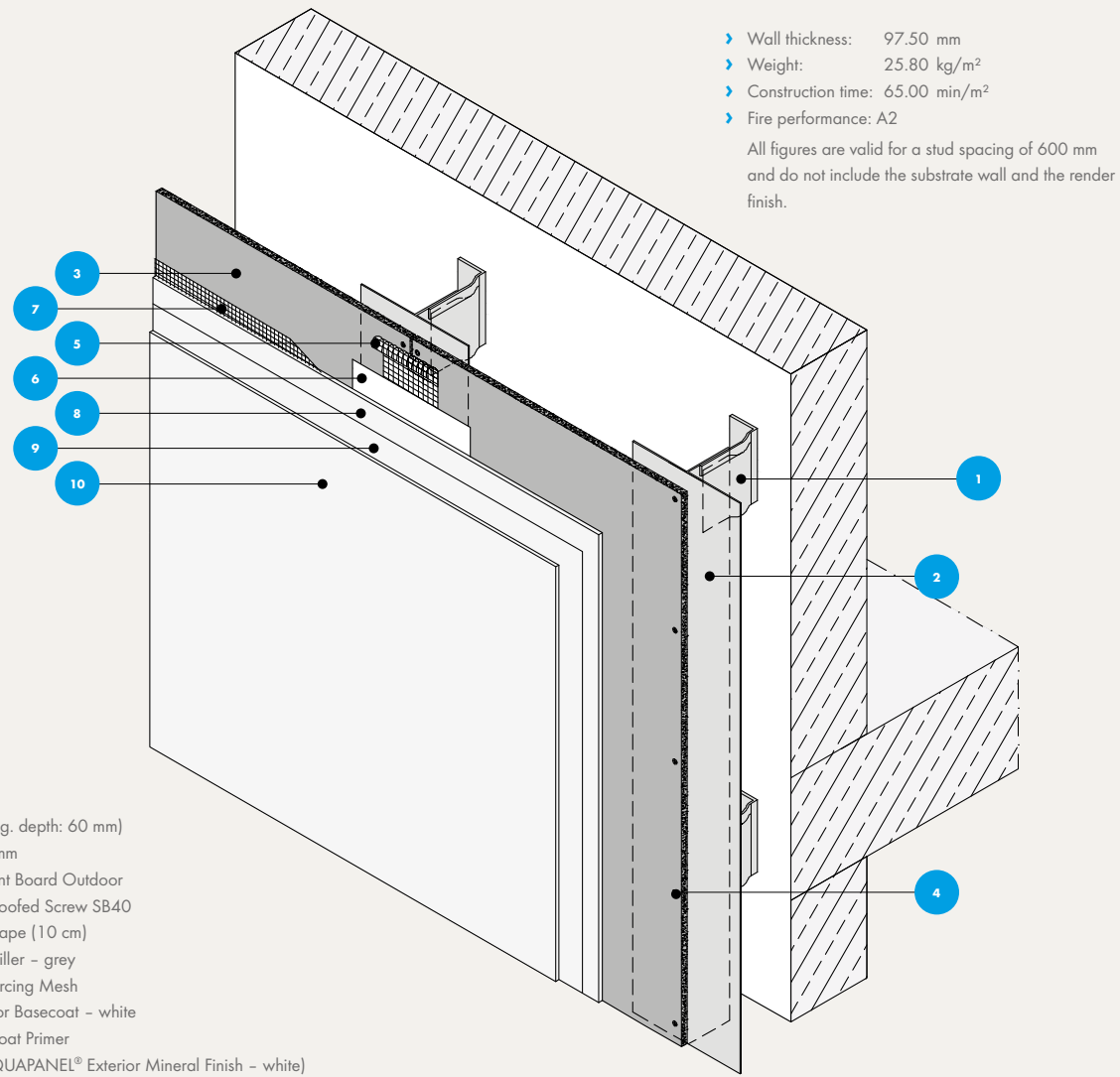

Characteristics of the construction

- > Renovation of solid building constructions. Especially suitable for large façade surfaces.
- > Structural separation of weather and thermal insulation.
- > Building physics suitable for residential and non-residential buildings (≥19°C), e. g. residential buildings, office buildings, hotels, hospitals, schools, etc.

Particularities for the assembly

- > The aluminum wall cleats are not to be thermally decoupled from the substrate.
- > The cladding surface have to be separated in areas of 15 x 15 m.
- > An application of the AQUAPANEL® Water Barrier is not essential, potentially accumulating moisture is quickly removed or dried in the ventilation gap.

CONSTRUCTION DRAWINGS

Section overview

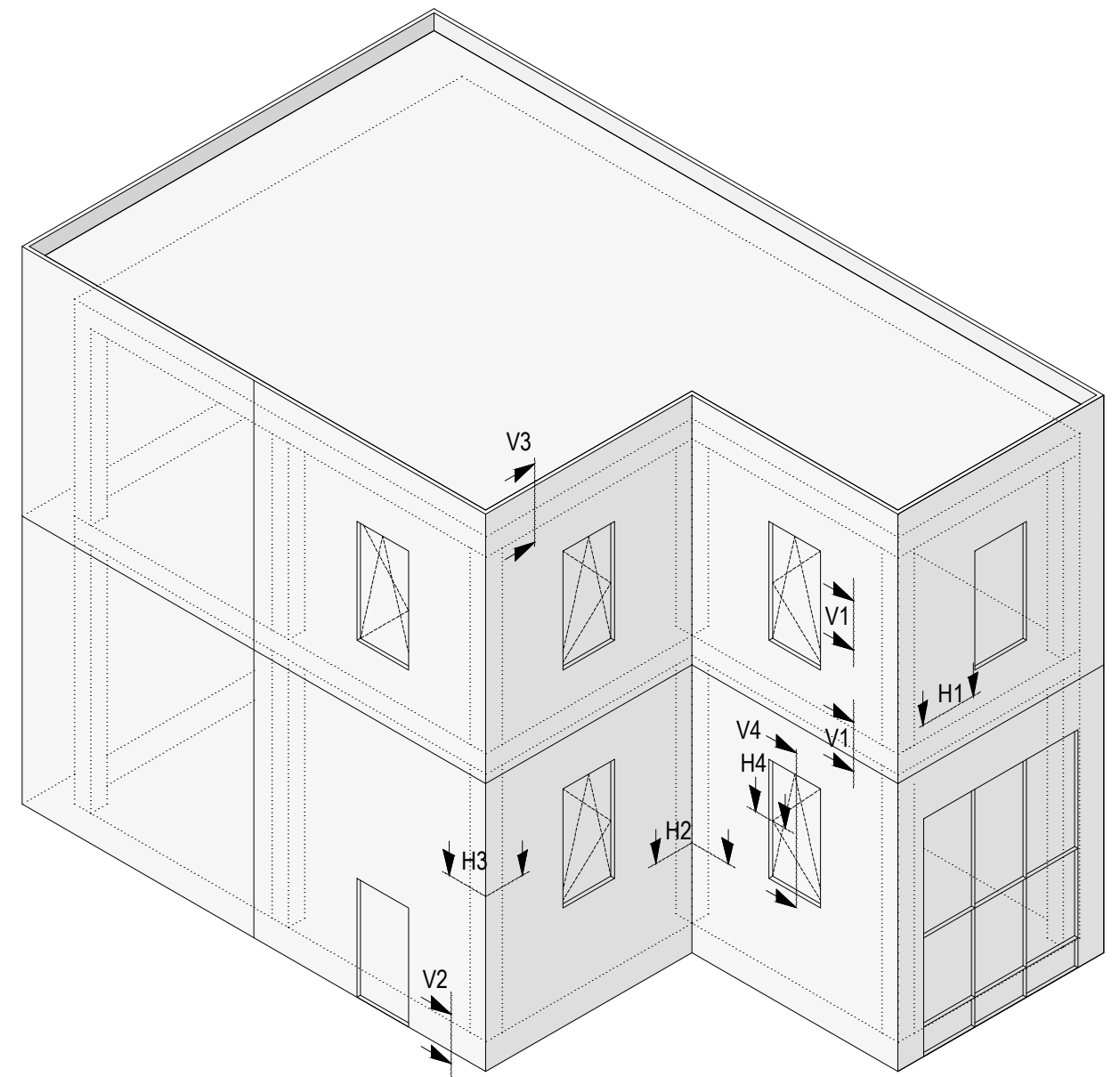

Index	Description
V1	Main section, vertical
V2	Vertical section - connection to base
V3	Vertical section - connection to parapet
V4.1	Vertical section window, lintel
V4.2	Vertical section window, parapet
H1	Main section, horizontal
H2	Horizontal section - interior corner without expansion joint
H3	Horizontal section - exterior corner without column
H4	Horizontal section window

Notes

- › The drawings illustrating the general concept of how the system works and interfaces with other construction components.
- › The drawings do not substitute an execution design.
- › Follow the local standards and guidelines for the planning and structural design.
- › The technical specifications and information on the products given in the technical data sheets and system descriptions / approvals must be observed.

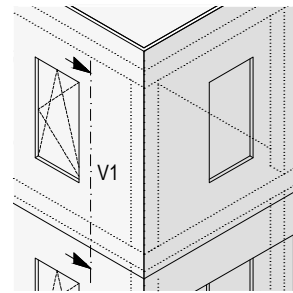

V1 Vertical section

Details scale 1:5

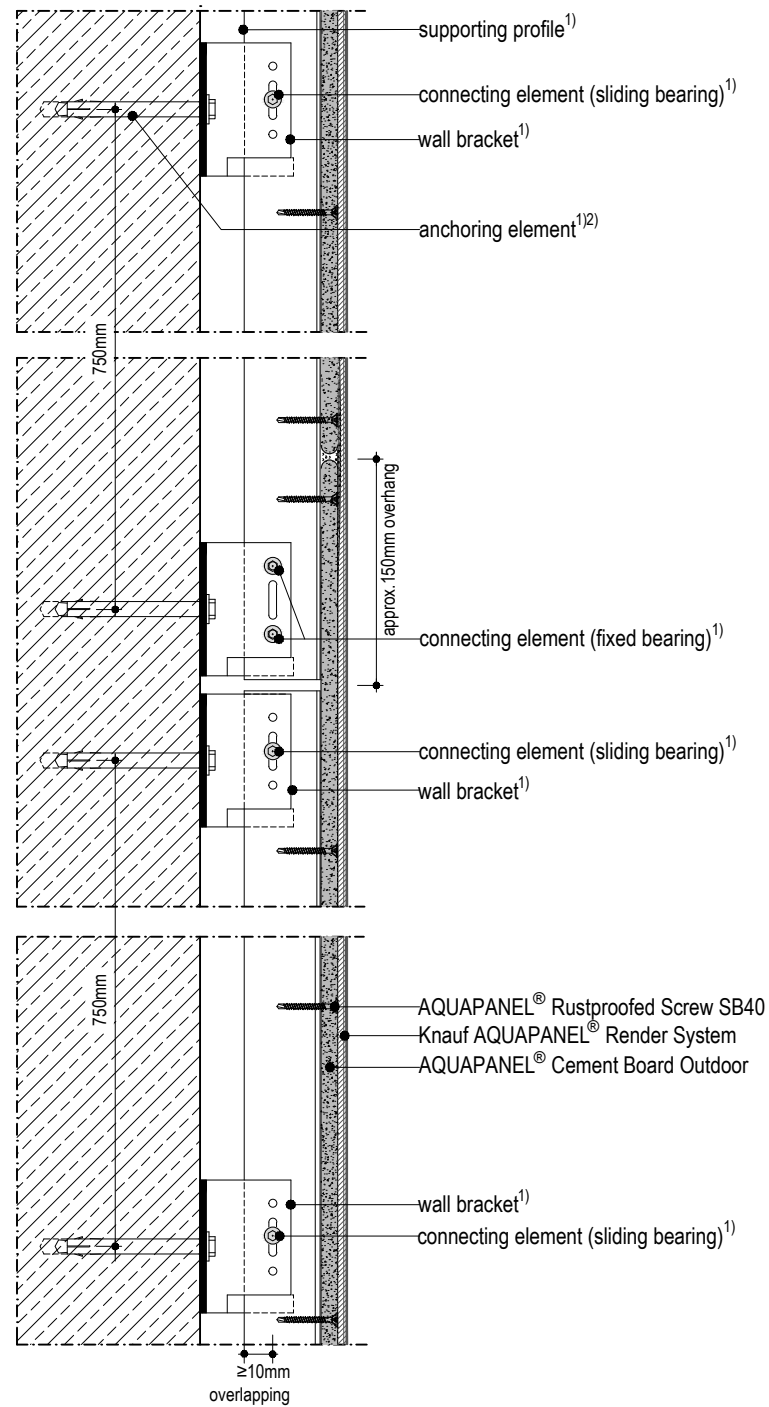

¹⁾according to static wcalculation ²⁾observe edge distance!

Notes

- › The drawings illustrating the general concept of how the system works and interfaces with other construction components.
- › The drawings do not substitute an execution design.
- › Follow the local standards and guidelines for the planning and structural design.
- › The technical specifications and information on the products given in the technical data sheets and system descriptions / approvals must be observed.

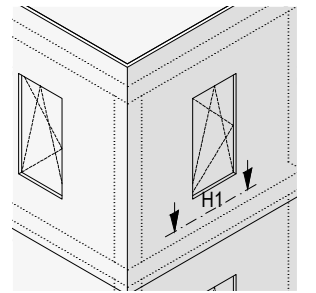

H1 Horizontal section with panel edge

Details scale 1:5

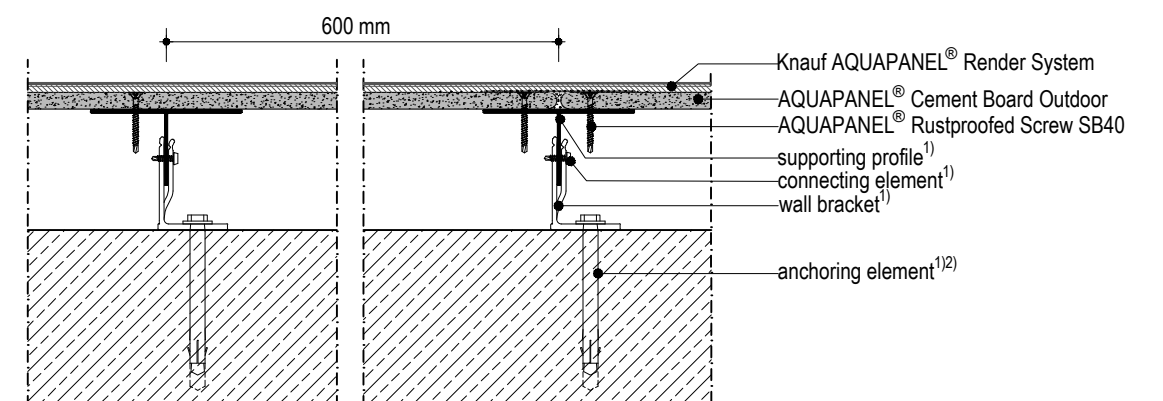

¹⁾according to static calculation ²⁾observe edge distance!

Notes

- › The drawings illustrating the general concept of how the system works and interfaces with other construction components.
- › The drawings do not substitute an execution design.
- › Follow the local standards and guidelines for the planning and structural design.
- › The technical specifications and information on the products given in the technical data sheets and system descriptions / approvals must be observed.

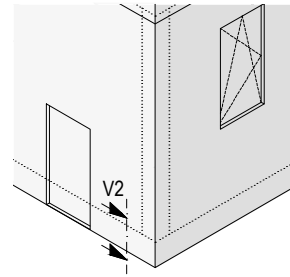

Details scale 1:5

V2 Vertical section - connection to base

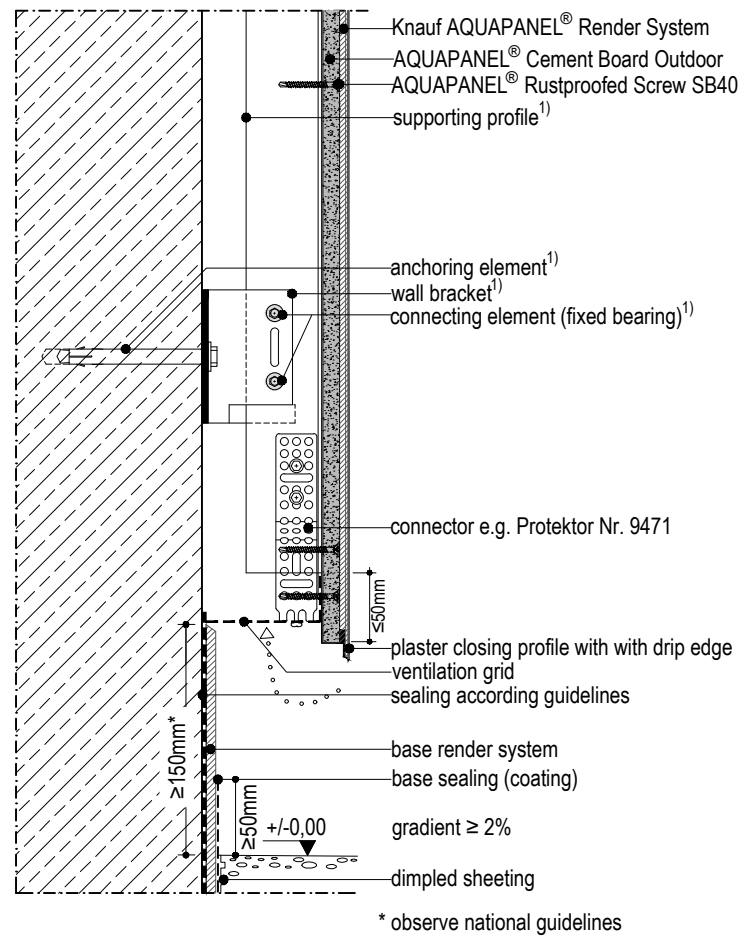

¹⁾according to static calculation

²⁾observe edge distance!

Notes

- › The drawings illustrating the general concept of how the system works and interfaces with other construction components.
- › The drawings do not substitute an execution design.
- › Follow the local standards and guidelines for the planning and structural design.
- › The technical specifications and information on the products given in the technical data sheets and system descriptions / approvals must be observed.

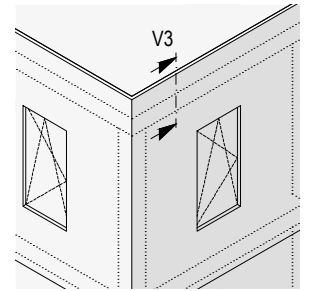

Details scale 1:5

V3 Vertical section - connection to parapet

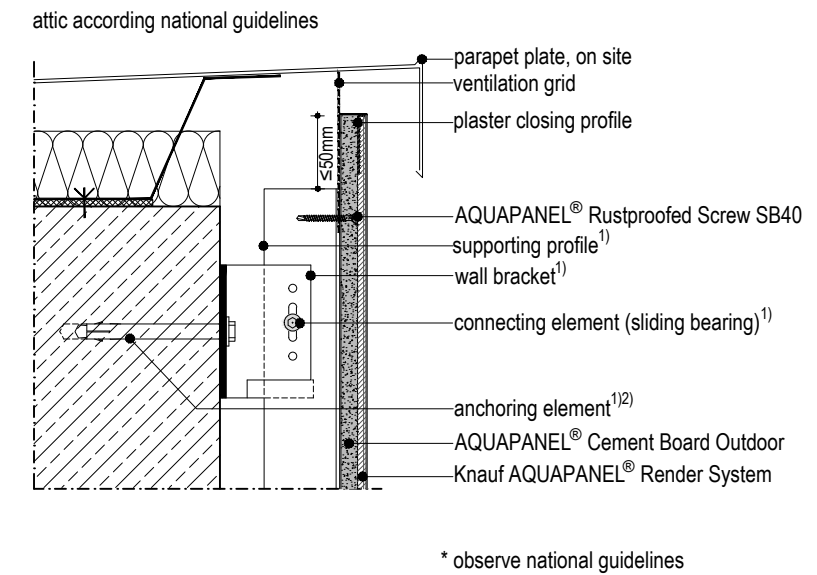

¹⁾according to static calculation

²⁾observe edge distance!

Notes

- › The drawings illustrating the general concept of how the system works and interfaces with other construction components.
- › The drawings do not substitute an execution design.
- › Follow the local standards and guidelines for the planning and structural design.
- › The technical specifications and information on the products given in the technical data sheets and system descriptions / approvals must be observed.

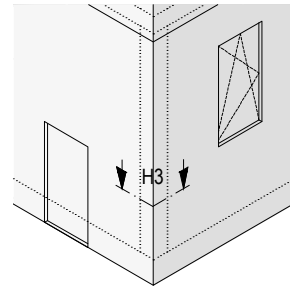

H3 Horizontal section - exterior corner without column

Details scale 1:5

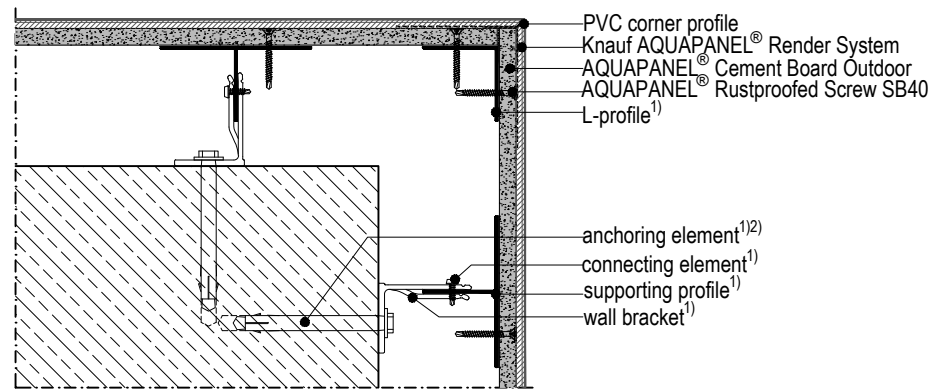

Notes

- › The drawings illustrating the general concept of how the system works and interfaces with other construction components.
- › The drawings do not substitute an execution design.
- › Follow the local standards and guidelines for the planning and structural design.
- › The technical specifications and information on the products given in the technical data sheets and system descriptions / approvals must be observed.

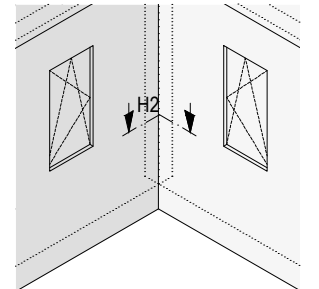

H2 Horizontal section - interior corner without expansion joint

Details scale 1:5

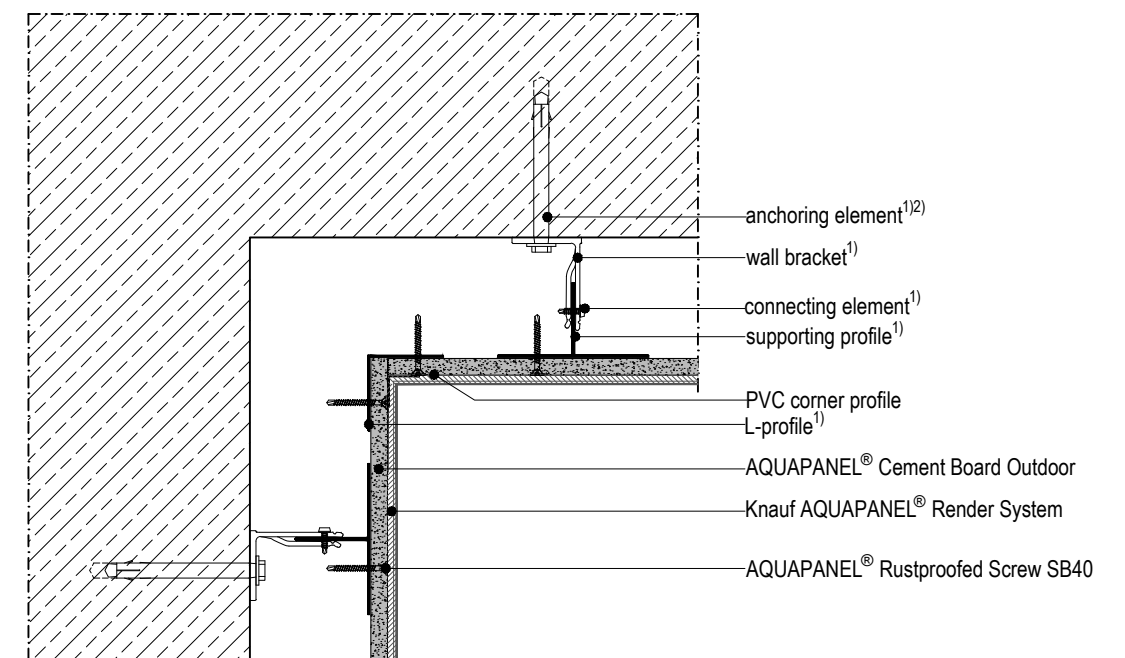

¹according to static calculation ²observe edge distance!

¹according to static calculation ²observe edge distance!

Notes

- › The drawings illustrating the general concept of how the system works and interfaces with other construction components.
- › The drawings do not substitute an execution design.
- › Follow the local standards and guidelines for the planning and structural design.
- › The technical specifications and information on the products given in the technical data sheets and system descriptions / approvals must be observed.

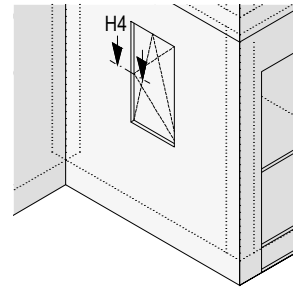

H4 Horizontal section - window

Details scale 1:5

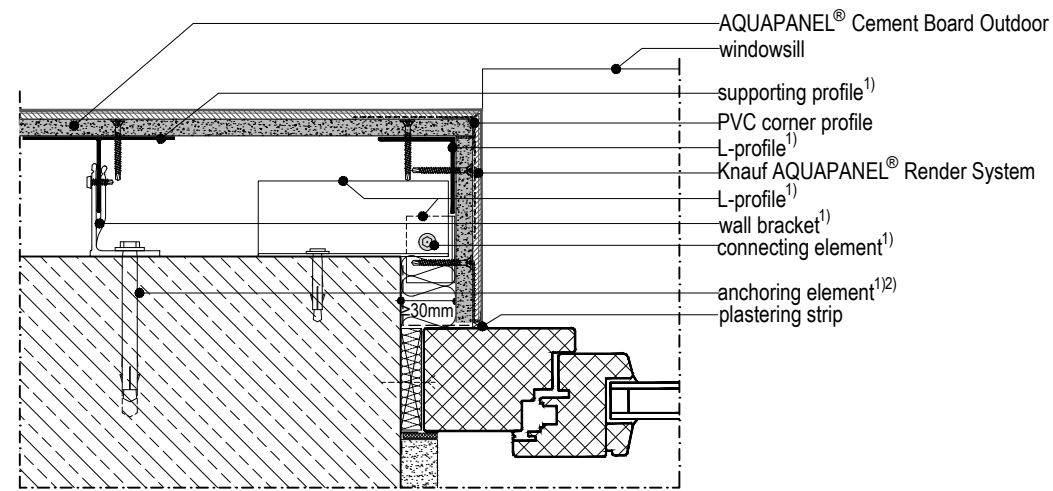

¹⁾according to static calculation

²⁾observe edge distance!

Notes

- › The drawings illustrating the general concept of how the system works and interfaces with other construction components.
- › The drawings do not substitute an execution design.
- › Follow the local standards and guidelines for the planning and structural design.
- › The technical specifications and information on the products given in the technical data sheets and system descriptions / approvals must be observed.

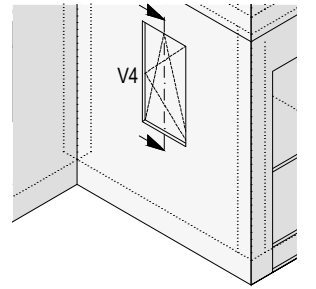

V4.1 Vertical section - lintel

Details scale 1:5

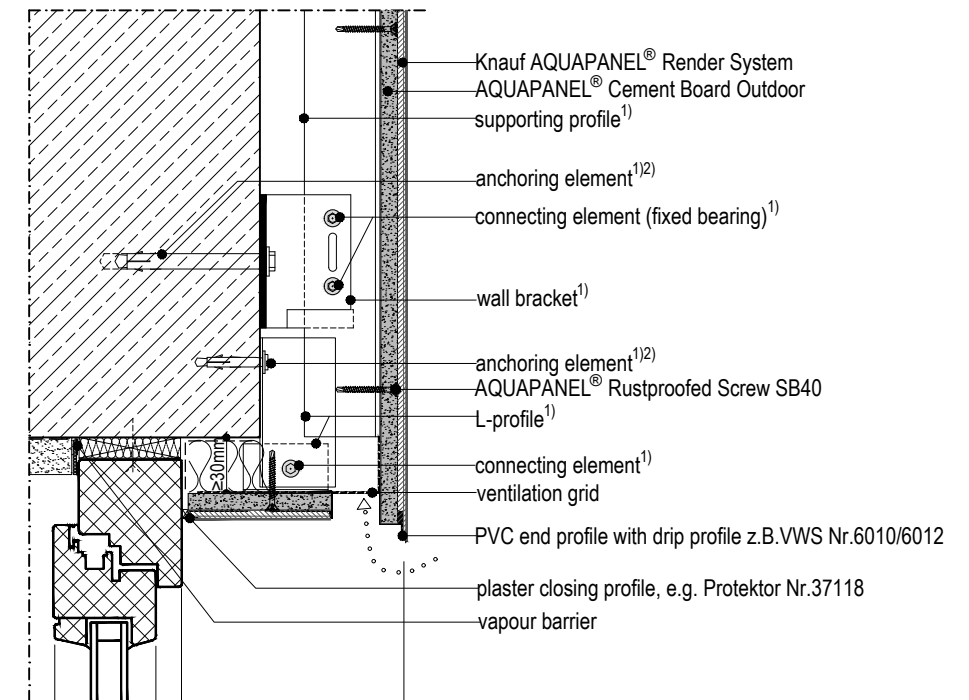

V4.2 Vertical section - parapet

Details scale 1:5

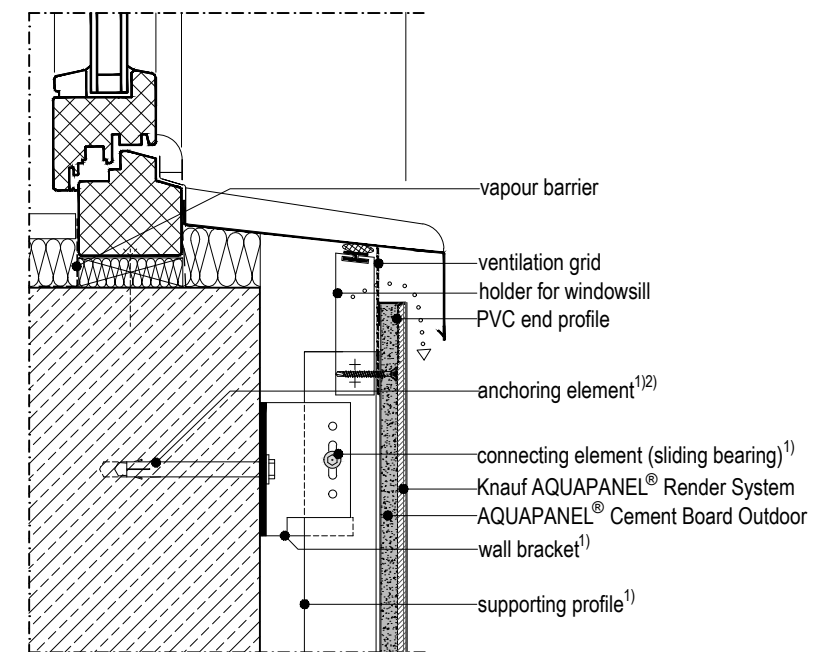

¹⁾according to static calculation

²⁾observe edge distance!

SPECIFICATIONS

Legend for text selections	
Optional items	Orange
Information to be supplemented by the contracting party	Blue

Item	Quantity	Performance description	Unit price	Total price
1		<p>KNAUF AQUAPANEL® VHF, rear ventilated rainscreen system without insulation, type WL132C.2.</p> <p>Rear-ventilated rainscreen system with cement-bonded board as exterior planking; inorganic and approved according to the building regulation, as substrate for different finishing materials and options; application in accordance with the manufacturer’s guidelines.</p> <p>Façade substructure in front of a massive substrate, adjustable in three dimensions.</p> <p>The rear-ventilated rainscreen system consists of aluminum profiles, fixed to the substrate with aluminium wall cleats (friction-locked and tension free connection by forming fixing and sliding points); type, dimension and quantity of the aluminium profiles, wall cleats, fasteners and fixing elements depending on structural requirements and to be approved according to the building regulations.</p> <p>The substructure is to be aligned accurately and delivered as well as installed according to the following specification. The material compatibility and the corrosion protection in particular of the connecting and anchoring elements have to be ensured accordingly.</p> <p>The following formal dimensions and cross-sections are minimum requirements. The application has to be carried out according to a verifiable structural analysis.</p> <p>Constructional specifications: Specification of the substrate for the anchoring Type/Quality/Wall thickness</p>		

Delete as applicable

Legend for text selections	
Optional items	Orange
Information to be supplemented by the contracting party	Blue

Item	Quantity	Performance description	Unit price	Total price
1.10		<p>Aluminium substructure</p> <p>Mount the aluminium substructure to the existing anchorage substrate (concrete, masonry, etc.) using wall brackets and anchoring elements. Fixing and sliding points have to be formed to allow a friction-locked and tension free fixation.</p> <p>Façade cantilever: xxx mm</p> <p>Aligned accurately; type, dimension and quantity of the wall cleats, fasteners and fixing elements depending on structural requirements and to be approved according to the building regulations.</p> <p>The cladding is specified in a separate item.</p> <p>Deliver, construct and assemble according to the enclosed planning and documentation in accordance with the manufacturer’s instructions, complete and ready-made.</p> <p>000,000 m</p>		

Delete as applicable

Legend for text selections	
Optional items	Orange
Information to be supplemented by the contracting party	Blue

Item	Quantity	Performance description	Unit price	Total price
1.20		<p>Façade cladding consisting of:</p> <p>AQUAPANEL® Cement Board Outdoor with AQUAPANEL® Rustproofed Screw SB40, AQUAPANEL® Joint Tape (10 cm) and AQUAPANEL® Joint Filler – grey, AQUAPANEL® Exterior Basecoat – white with AQUAPANEL® Reinforcing Mesh.</p> <p>Including all plaster and finishing profiles as well as corner beads.</p> <p>Deliver, construct and assemble according to the enclosed planning and documentation in accordance with the manufacturer’s instructions, complete and ready-made.</p> <p>000,000 m²</p>		
1.30		<p>In addition – window opening</p> <p>The construction of a window opening, in addition to item 1.10, incl. connection work to the windows and window sills, interior and exterior.</p> <p>Opening size: L X W Other: Incl. all render profiles, sealing tapes, corner protection profiles, diagonal render reinforcements, etc.</p> <p>Deliver, construct and assemble according to the enclosed planning and documentation in accordance with the manufacturer’s instructions, complete and ready-made.</p> <p>000,000 Unit</p>		

Delete as applicable

Legend for text selections	
Optional items	Orange
Information to be supplemented by the contracting party	Blue

Item	Quantity	Performance description	Unit price	Total price
1.40		<p>In addition – door/gate opening</p> <p>The construction of a door/gate opening, in addition to item 1.10, incl. connection work to the door/gate, interior and exterior.</p> <p>Opening size: L X W Other: Incl. all render profiles, sealing tapes, corner protection profiles, diagonal render reinforcements, etc.</p> <p>Deliver, construct and assemble according to the enclosed planning and documentation in accordance with the manufacturer’s instructions, complete and ready-made.</p> <p>000,000 Unit</p>		
1.50		<p>In addition – metal-glass façade (Column and beam construction)</p> <p>The construction of an opening for a metal-glass façade, in addition to item 1.10 incl. connection work to the metal-glass façade, interiors and exteriors.</p> <p>Opening size: L X W Other: Incl. all render profiles, sealing tapes, corner protection profiles, diagonal render reinforcements, etc.</p> <p>Deliver, construct and assemble according to the enclosed planning and documentation in accordance with the manufacturer’s instructions, complete and ready-made.</p> <p>000,000 m</p>		
1.60		<p>In addition – on-site penetration</p> <p>Construction of a penetration in addition to item 1.10 (e.g. pipes, emergency spillways, etc.), incl. connection work; use suitable sealing material, e. g. Compriband or similar, exteriors.</p> <p>Opening size: L X W Other: Incl. all plaster strips, sealing tapes, corner protection rails, diagonal reinforcements, etc.</p> <p>Deliver, construct and assemble according to the enclosed planning and documentation in accordance with the manufacturer’s instructions, complete and ready-made.</p> <p>000,000 m</p>		

Delete as applicable

Legend for text selections	
Optional items	Orange
Information to be supplemented by the contracting party	Blue

Item	Quantity	Performance description	Unit price	Total price
1.70		<p>In addition – outside corner of façade</p> <p>Construction of an external corner of a façade in addition to item 1.10, incl. all corner profiles, etc.</p> <p>Deliver, construct and assemble according to the enclosed planning and documentation in accordance with the manufacturer’s instructions, complete and ready-made.</p> <p>000,000 m</p>		
1.80		<p>In addition – inside corner of façade</p> <p>Construction of an internal corner of a façade in addition to item 1.10, incl. corner reinforcement, etc.</p> <p>Deliver, construct and assemble according to the enclosed planning and documentation in accordance with the manufacturer’s instructions, complete and ready-made.</p> <p>000,000 m</p>		
1.90		<p>In addition – expansion joint (horizontal/vertical)</p> <p>Construction of system-related expansion joints in addition to item 1.10, incl. all expansion joint profiles.</p> <p>Deliver, construct and assemble according to the enclosed planning and documentation in accordance with the manufacturer’s instructions, complete and ready-made.</p> <p>000,000 m</p>		
1.100		<p>In addition – structural joint</p> <p>Construction of a structural joint in addition to item 1.10, incl. all expansion joint profiles.</p> <p>Deliver, construct and assemble according to the enclosed planning and documentation in accordance with the manufacturer’s instructions, complete and ready-made.</p> <p>000,000 m</p>		

Delete as applicable

Legend for text selections	
Optional items	Orange
Information to be supplemented by the contracting party	Blue

Item	Quantity	Performance description	Unit price	Total price
1.110		<p>*** Optional item</p> <p>In addition – horizontal fire barrier</p> <p>Construction of a horizontal fire barrier in addition to Item 1.10.</p> <p>Horizontal fire barrier according to local guidelines for rear-ventilated rainscreen systems.</p> <p>In the case of fire the horizontal fire barriers have to be dimensionally stable for at least 30 minutes. (e.g. steel sheet with a thickness of $d \geq 1$ mm). Plan and coordination with a fire safety expert.</p> <p>Deliver, construct and assemble according to the enclosed planning and documentation in accordance with the manufacturer’s instructions, complete and ready-made.</p> <p>000,000 m</p>		
1.120		<p>*** Optional item</p> <p>In addition – vertical fire barrier</p> <p>Construction of a vertical fire barrier in addition to item 1.10.</p> <p>Vertical fire barrier according to local guidelines for rear-ventilated rainscreen systems.</p> <p>The ventilation gap is not to be continued at the fire wall; the vertical fire barrier consists of dimensionally stable insulation material (with melting point $> 1,000^\circ\text{C}$) and has to cover at least the fire wall thickness.</p> <p>Deliver, construct and assemble according to the enclosed planning and documentation in accordance with the manufacturer’s instructions, complete and ready-made.</p> <p>000,000 m</p>		

Delete as applicable

Legend for text selections	
Optional items	Orange
Information to be supplemented by the contracting party	Blue

Item	Quantity	Performance description	Unit price	Total price
1.1		Surface treatment – exterior façade		
1.1.10		<p>Priming of façade surface</p> <p>Priming of the façade surface with application of the system-compatible AQUAPANEL® Basecoat Primer; prime the entire surface.</p> <p>Miscellaneous: incl. reveals and lintels</p> <p>Deliver, construct and assemble according to the enclosed planning and documentation in accordance with the manufacturer’s instructions, complete and ready-made.</p> <p>000,000 m²</p>		
1.1.20		<p>Exterior finish</p> <p>Deliver AQUAPANEL® Exterior Mineral Finish – white, applied on entire surface, grain size 2 mm, structure and colour according to architect’s specification; align accurately and remove the render to grain size.</p> <p>Location: elevation no. : _____ axis no. : _____</p> <p>Colour: according to architect’s specification</p> <p>Miscellaneous: incl. reveals and lintels</p> <p>Deliver, construct and assemble according to the enclosed planning and documentation in accordance with the manufacturer’s instructions, complete and ready-made.</p> <p>000,000 m²</p>		

Delete as applicable

Legend for text selections	
Optional items	Orange
Information to be supplemented by the contracting party	Blue

Item	Quantity	Performance description	Unit price	Total price
1.1.30		<p>*** Optional item</p> <p>Exterior finish</p> <p>AQUAPANEL® Exterior Dispersion Plaster – white, applied on entire surface, structure and colour according to architect’s specification, align accurately and remove the render to grain size.</p> <p>Location: elevation no. : _____ axis no. : _____</p> <p>Colour: according to architect’s specification</p> <p>Miscellaneous: Incl. reveals and lintels</p> <p>Deliver, construct and assemble according to the enclosed planning and documentation in accordance with the manufacturer’s instructions, complete and ready-made.</p> <p>000,000 m²</p>		
1.1.40		<p>*** Optional item</p> <p>Exterior finish</p> <p>AQUAPANEL® Silicon Synthetic Resin Plaster – white, applied on entire surface, structure and colour according to architect’s specification, align accurately and remove the render to grain size.</p> <p>Location: elevation no. : _____ axis no. : _____</p> <p>Colour: according to architect’s specification</p> <p>Miscellaneous: Incl. reveals and lintels</p> <p>Deliver, construct and assemble according to the enclosed planning and documentation in accordance with the manufacturer’s instructions, complete and ready-made.</p> <p>000,000 m²</p>		

Delete as applicable

Legend for text selections	
Optional items	Orange
Information to be supplemented by the contracting party	Blue

Item	Quantity	Performance description	Unit price	Total price
1.2		Further services		
1.2.10		<p>*** Optional item: Scaffolding brackets</p> <p>GELOG scaffolding brackets for the described wall structure, dimensioning according to statics. Deliver, construct and assemble according to the enclosed planning and documentation in accordance with the manufacturer's instructions, complete and ready-made.</p> <p>000,000 Unit</p>		
1.2.20		<p>Detail and implementation planning</p> <p>Preparation of the detail and implementation planning, incl. the details and installation plans for the steel substructure and the AQUAPANEL® Cement Board Outdoor as well as the anchoring system.</p> <p>Before execution, all planning and construction results have to be signed off by the contractor and the structural engineer.</p> <p>1 lump sum</p>		
1.2.30		<p>Proof of stability</p> <p>Preparation of verifiable static calculation of the substructure, incl. screw connections, dowels, anchors, etc. This must be submitted by the contractor before start of execution and signed off by the responsible inspecting structural engineer.</p> <p>1 lump sum</p>		
1.2.40		<p>*** Optional item: Mock-up</p> <p>Creation of a complete mock-up, Size: approx. a x b m Location: elevation no. : _____ axis no. : _____</p> <p>Mock-up for subsequent incorporation into the façade / Mock-up has to be removed afterwards / Mock-up will be erected separately from site (location to be defined)</p> <p>If necessary in coordination with other disciplines as specified by the architect.</p> <p>Deliver, construct and assemble according to the enclosed planning and documentation in accordance with the manufacturer's instructions, complete and ready-made.</p> <p>1 lump sum</p>		

Delete as applicable

PRODUCT RANGE



Exterior lining

To ensure that the Knauf Exterior Wall acquires its water resistant properties, AQUAPANEL® Cement Board Outdoor is fixed onto the aluminium profiles of the rear-ventilated rainscreen facade system. It is complemented with specially developed system accessories including AQUAPANEL® Joint Filler, AQUAPANEL® Tape as well as AQUAPANEL® Rustproofed Screws, the result is a complete - and completely reliable - lining system of AQUAPANEL® products.

Cement boards		Width (mm)	Length (mm)	Thickness (mm)	Weight (approx kg/m²)
AQUAPANEL® Cement Board Outdoor 	<ul style="list-style-type: none"> ▶ Cement board ▶ Easy Edge™ ▶ Building material class: A1, non-combustible ▶ 100% water resistant ▶ Bending radius 1-3m (in dry state) 	900	1,200	12.5	16
		900	1,250		
		900	2,400		
		900	2,500		
		1,200	900		
		1,200	2,000		
		1,200	2,400		
		1,200	2,500		
		1,200	2,800		
		1,200	3,000		
		1,250	900		
		1,250	2,000		
1,250	2,500				



Screws		Length (mm)
AQUAPANEL® Rustproofed Screw SN40 	<ul style="list-style-type: none"> ▶ With countersunk head and nail tip ▶ Stainless steel 	40

Joint filler		Coverage (ca kg/m²)	Storage life (approx month)	Weight (kgbag)
AQUAPANEL® Joint Filler – grey 	<ul style="list-style-type: none"> ▶ Cement-bound joint filling material ▶ Full-surface skimcoating of joints ▶ Reinforced with AQUAPANEL® Tape 10cm 	0.7	12	20

Joint tapes		Width (mm)	Roll length (mm)
AQUAPANEL® Tape 10cm 	<ul style="list-style-type: none"> ▶ Glass fabric joint tape ▶ Alkali-resistant coating ▶ Colour: blue ▶ Mesh size: 4x4mm 	100	50,000
			20,000
AQUAPANEL® Exterior Reinforcing Tape 	<ul style="list-style-type: none"> ▶ Glass fabric joint tape ▶ Alkali-resistant coating ▶ Colour: blue ▶ Mesh size: 4x4mm 	200	50,000

Exterior finishing

Knauf Exterior Wall is able to accommodate a wide range of finishes, so whatever you want to achieve, it's achievable. In terms of render, AQUAPANEL® has a range of products in its portfolio, including AQUAPANEL® Exterior Basecoat, AQUAPANEL® Reinforcing Mesh, AQUAPANEL® Basecoat Primer and a range of finishing renders. In addition, Knauf offers a selection of renders to increase choice and design possibilities. Knauf Exterior Wall is also compatible with a wide range of third-party finishes, including cladding, brick slips, tiles and paint, so there is no limit on design potential.

Basecoats			Coverage (ca kg/m ²)	Storage life (approx month)	Weight (kg/bag)
AQUAPANEL® Exterior Basecoat		<ul style="list-style-type: none"> › Cement-based, synthetic resin-enhanced basecoat › Colour: grey › Used for basecoating AQUAPANEL® Cement Board Outdoor when finishing with a thin layer of finishing plaster, decorative render or paint 	7.8 (with 5mm layer thickness)	12	25
AQUAPANEL® Exterior Basecoat – white		<ul style="list-style-type: none"> › Cement-based, synthetic resin-enhanced basecoat › Colour: white › Used for basecoating AQUAPANEL® Cement Board Outdoor when finishing with a thin layer of finishing plaster, decorative render or paint 	6.3 (with 5mm layer thickness)	12	25
Reinforcing mesh			Width (mm)	Roll length (mm)	
AQUAPANEL® Reinforcing Mesh		<ul style="list-style-type: none"> › Alkali-resistant coating › Colour: blue › Used to reinforce AQUAPANEL® Exterior Basecoat and AQUAPANEL® Exterior Basecoat – white › Mesh size: 4x4mm › Initial tear strength: approx. 2200 N/5cm › Approx. 160g/m² 	1,000	50,000	

Basecoat primer			Coverage (approx kg/m ²)	Storage life (approx month)	Weight (kg/bucket)
AQUAPANEL® Basecoat Primer		<ul style="list-style-type: none"> › Synthetic dispersion › Alkali-resistant › Colour: white › Used as a primer on AQUAPANEL® Exterior Basecoat and AQUAPANEL® Exterior Basecoat – white where AQUAPANEL® render finishes are used › Reduces suction variations 	7.8 (with 5mm layer thickness)	12	15
Finishing renders			Coverage (approx kg/m ²)	Storage life (approx month)	Weight (kg/unit)
AQUAPANEL® Exterior Mineral Finish – white		<ul style="list-style-type: none"> › Mineral finishing render › For use on top of AQUAPANEL® Exterior Basecoat and AQUAPANEL® Exterior Basecoat – white › Grain size: 2mm › Can be used as a smooth floating finishing render or freely structured using different tools and designs 	3.0 (with 2mm layer thickness)	12	30
AQUAPANEL® Exterior Dispersion Plaster – white		<ul style="list-style-type: none"> › Ready-to-use › Pasty consistency › Water-repellent › Allows diffusion › Prevents fungal attack › For application on AQUAPANEL® Exterior Basecoat and AQUAPANEL® Exterior Basecoat – white › Grain size: 2mm 	3.1	24	25
AQUAPANEL® Exterior Silicon Synthetic Resin Plaster – white		<ul style="list-style-type: none"> › Ready-to-use › Pasty consistency › Water-repellent › Allows diffusion › Prevents fungal attack › For application on AQUAPANEL® Exterior Basecoat and AQUAPANEL® Exterior Basecoat – white › Grain size: 2mm 	3.1	24	25



PRODUCT HANDLING

Boards



- › Always carry the boards upright, or use board rollers. Handle with fork lift or crane as palletted goods. Take care not to damage corners and edges when setting the boards down. Place boards down on their long edge before laying them flat.

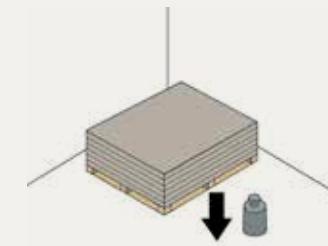

- › Ensure that the base is strong enough to support the boards.



- › Protect boards from moisture and weathering before they are installed. Boards which have become damp must be dried on both sides on a flat surface prior to fitting. Before installing, condition the boards to the ambient temperature and humidity.

Profiles



- › Protect profiles from moisture and weathering before they are installed. Products should not be left permanently exposed to the elements.

Powder materials



- › Store bags in a dry place and in original packaging.

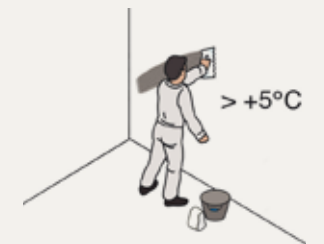

- › Do not apply joint fillers, basecoat or finishing materials in temperatures less than +5°C.

Health and safety

- › Avoid unnecessary dust on job site when using electrical saw. Keep sanding and other dust generation to a minimum. Maintain adequate ventilation and/or wear suitable protection.
- › Exercise care when using power tools and take all necessary precautions.
- › Follow instructions on packaging when applying system accessories.
- › When using powdered products, mix with water in well-ventilated conditions. Avoid contact with eyes and skin. In the event of contact with the eyes, irrigate with plenty of clean water immediately.
- › When handling insulation or cutting boards which contain glassfibre, wear suitable protection including face mask and gloves. Wear protective glasses when working overhead.
- › Follow national health and safety regulations at all times.

The product data sheets and material safety data sheets are available on our website www.AQUAPANEL.com/downloads.



INSTALLATION

1. Installing the substructure and insulation

The building envelope is subject to certain geometric and dimensional tolerances. The rear ventilated rainscreen facade is exceptionally well-suited to compensate these tolerances. The demanded facade distance on each side of the building correspond to the minimum distance between outer edge of the massive wall and outer edge of the facade cladding.

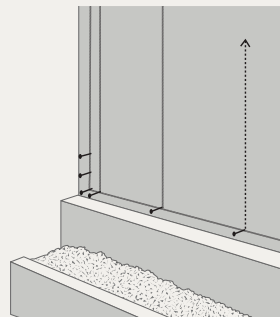
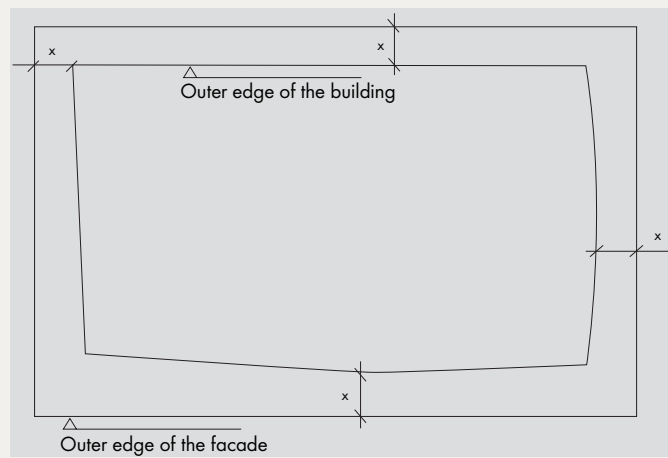

1.1 For the correct alignment of the Knauf Exterior Wall, determine the vertical axes for the support profiles (T- and L-profiles) via chalk line tool, cross-line laser or rotating laser. The horizontal distance between neighboring profiles is in maximum 600 mm.

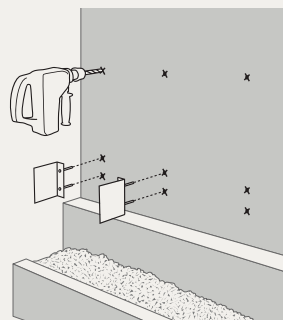
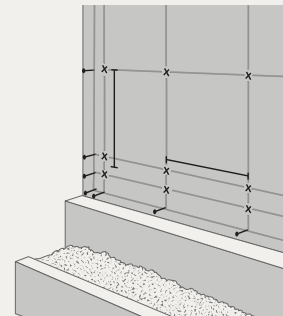

1.2 Mark the boreholes for the anchoring elements in accordance with statics and laying plan (including arrangement of movement joints). Determine the vertical distance between the aluminium brackets according to static calculation. Be aware that the brackets are mounted in a horizontally reciprocal layout from profile to profile.

1.3 Use an appropriate drilling machine to drill holes into the reinforced concrete for the anchors. Use approved anchoring means according to local building regulations (fire resistance) and static requirements (type and quantity of fasteners). Please respect the mandatory borehole diameters and depths for the screw anchors.

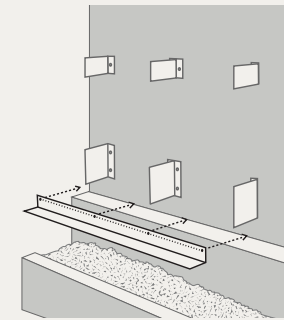

1.4 Arrange aluminium brackets to create sliding and fixing points; use thermal decoupling elements; fix with appropriate anchoring elements. When using galvanized anchoring elements, the screw heads have to be fully covered by a permanently elastic bituminous oil coating after installation to prevent intrusion of moisture into the anchor shaft. Make dowel extraction tests, when substrate is unclear. Install a continuous system bracket (for later incorporation of the ventilation profile) at the base area. Underlay it with thermal separating elements. Build the substructure for lintel, parapet and reveals of the window openings with support profiles (L-profile) underlaid with thermal separating

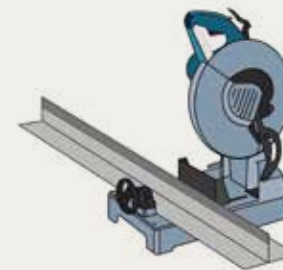

1.5 Cut support profiles (T- and L-profiles) to appropriate length using electric separating tools.

› Straightening - Alternative 1: Mason's Lacing Cord

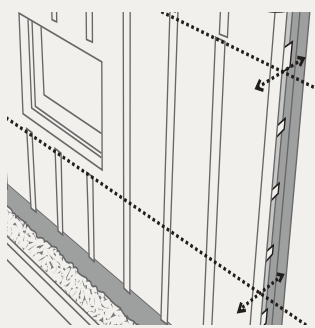

1.6 Fasten AQUAPANEL® Rustproofed Screw SB40 into the flanges at the top and bottom ends of every profile of the outermost profile axes of each exterior wall surface for temporarily fixing the cords. First fix the cords vertically at the top and bottom of the outermost axes. Straighten the profiles until they are in line with the cords. Then fix the cords horizontally to straighten the residual profiles.

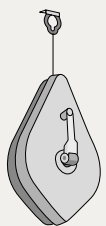

› Straightening - Alternative 2: Rotating Laser:

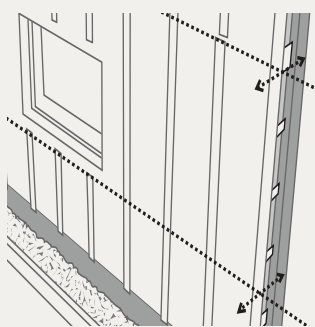

1.6 You can also use a rotating laser with a receiver to vertically display a straight line to which you can comply for a correct alignment of each profile.



To permanently fix the support profiles to the wall holders with connecting element, start in the base area to create a fixing point. After that work your way upwards to create sliding points.

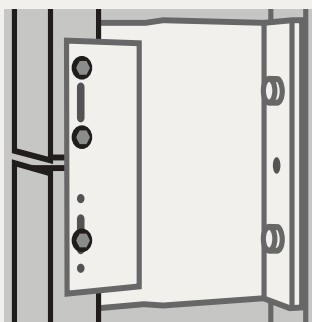

1.7 Fix the support profiles (T- and L-profiles) to the brackets. Be aware of the necessary horizontal joints (10mm) between the profiles in the area of the brackets to create a sliding point for the lower profile and a fixing point for the upper profile.

Note: Install the ventilation angle onto the system bracket at the base area and use a connector to fix it directly to the webs of the support profiles.

2. Exterior Board Installation



2.1 Mark the desired shape or opening on the board with pencil and ruler. Use a knife to score the cement or gypsum boards on one side along the line so that the mesh resp. thick paper is cut. Snap the scored edge and cut the mesh/paper on the rear side.



2.2 For sharp-edged cuts, for example, exterior edges, use a hand-held circular saw with a dust extractor or a pendulum jigsaw. Use of a carbide or diamond-tipped saw blade is recommended.

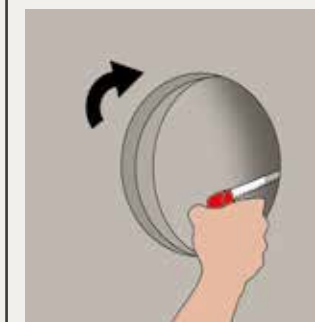

2.3 To make cut-outs for wiring and pipes, use a jigsaw or hole saw. The diameter of the opening should be approximately 10 mm greater than the diameter of the pipe. The remaining gap can be closed with a cuff, suitable sealant or sealing strip.

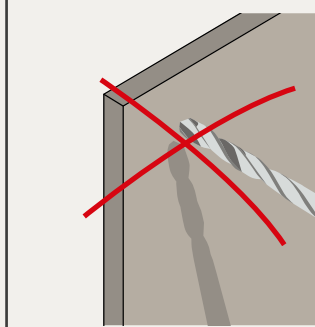
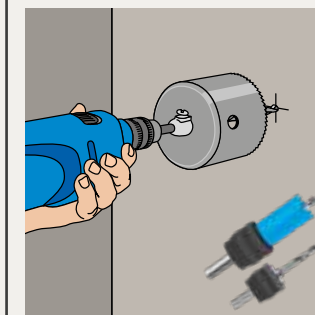

2.4 Generally, no pre-drilling of boards is required. However, pre-drilling of boards and profiles is needed, when blind rivets are used instead of screws.

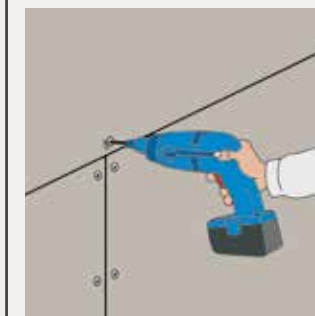

2.5 To fasten the boards with screws use a screw gun with depth stop (comprising overturned sleeve and a stop sleeve). This ensures that all screws are countersunk in the same correct way. Fasten AQUAPANEL® Cement Board Outdoor to the profiles with AQUAPANEL® Rustproofed Screws SB40. First fasten the screws in the centre of the cement boards, then work towards the edges. During installation, make sure the cement boards fit closely to the substructure. Screws should not be overtightened.



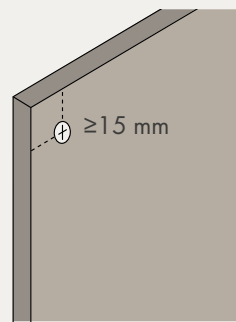

2.6 Follow rules of distances: the screw spacing must not exceed 250 mm and the spacing from the edge has to be at least 15 mm.

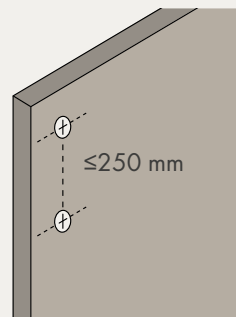

2.7 Apply AQUAPANEL® Cement Board Outdoor panels horizontally. Arrange front edge joints (vertical) on centre of profile flanges. Leave a gap of 3-5 mm between boards alongside the long and front edges (horizontal and vertical) using a suitable spacer. Front edge joints (vertical) must be staggered by at least one stud spacing.

Note: Hairline cracks on the surface of the AQUAPANEL® Cement Board Outdoor are no indications of loss of strength or function, as long as embedded glass fibre mesh is intact.

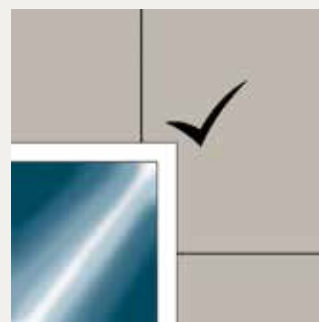

2.8 Take the boards up to the parapet, reveals and parapet of the window or the door. There must be no continuous joints as these could lead to cracks and leaks. The spacing between the board joints and the imaginary extensions (horizontal and vertical) of the window frames has to be at least 150 mm.

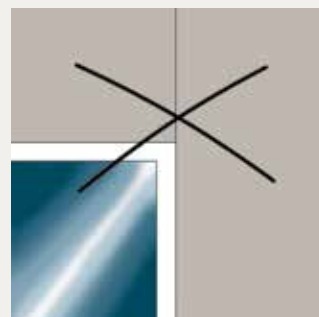

3. Joint Treatment



3.1 Immediately after fixing the boards, protect the wall from weathering by filling all the joints with AQUAPANEL® Joint Filler - grey. Use an agitator to mix the joint filler. A tool with 600 rpm is recommended.

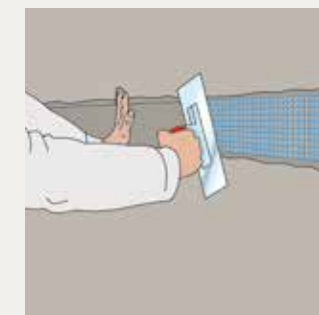
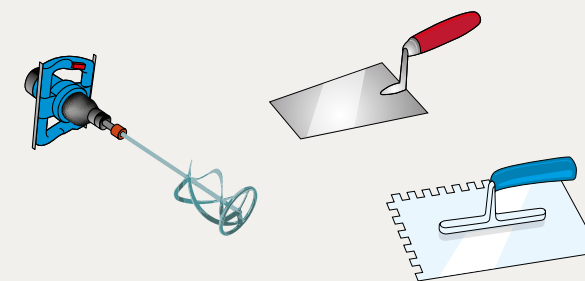

3.2 Right after that embed AQUAPANEL® Tape (10 cm) centred alongside all joints.

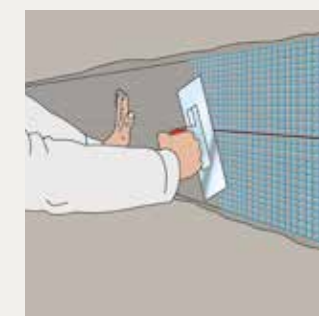

3.3 If later only one coat of paint is to be applied onto AQUAPANEL® Exterior Basecoat or AQUAPANEL® Exterior Basecoat - white, use AQUAPANEL® Exterior Reinforcing Tape which has a width of 20 cm.



3.4 Finally cover the screw heads with AQUAPANEL® Joint Filler - grey.

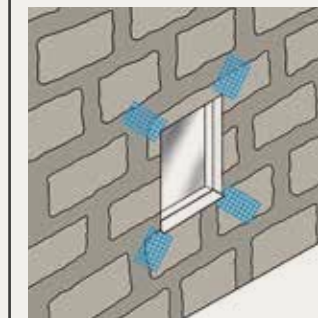

3.5 Reinforce the boards next to the door and window corners with a narrow strip of AQUAPANEL® Reinforcing Mesh (size 50 x 30 cm, applied at an angle of 45° to the corners - see picture).

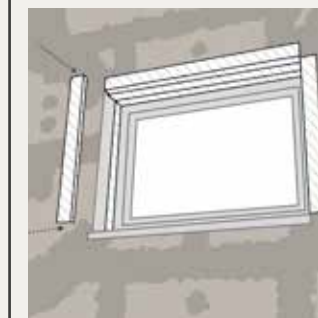

3.6 Mount appropriate PVC-plaster profiles at the corners and edges of the windows to protect them. Embed it in AQUAPANEL® Exterior Basecoat or AQUAPANEL® Joint Filler grey.

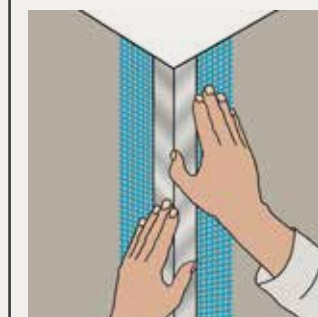

3.7 Outside corners are reinforced by applying a PVC-corner profile with AQUAPANEL® Exterior Basecoat or AQUAPANEL® Joint Filler - grey.

Note: In this state the building envelope is closed. The wall surface may now be freely exposed to the weather for up to six months, before applying render or other finishings. As a result, interior works (including screeding and the installation of stud frames, vapour barrier, lining and insulation) can progress. Before the exterior finishing, the boards only have to be cleaned and dried off.

4. Basecoat and Reinforcing Mesh

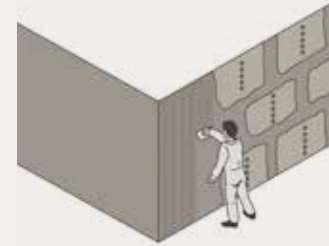

4.1 AQUAPANEL® Cement Board Outdoor must be rendered with AQUAPANEL® Exterior Basecoat or AQUAPANEL® Exterior Basecoat - white, when finishing options are painting, rendering or adhered finishes such as brickslips or tiles. The basecoat is applied by hand using a trowel (use an agitator with 600 rpm to mix) or by machine (machine recommendation: mixing pump PFT G4, rotor/stator D4-3, half power, water requirement 200 l/h).



4.2 When applying the AQUAPANEL® Exterior Basecoat, create a layer of average 5 mm thickness using a notched trowel of 10 x 10 mm.

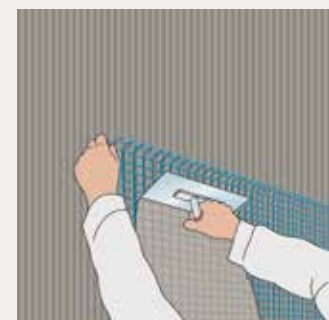

4.3 Gently embed/place the mesh. Overlap all joints of the mesh at least 10 cm.

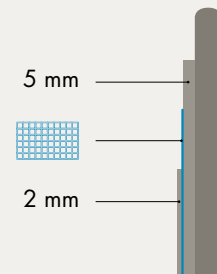
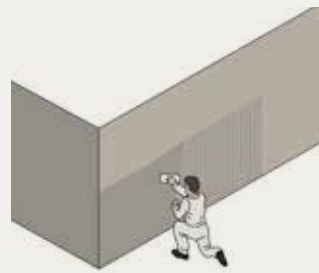

4.4 On top of the mesh add an extra 2 mm basecoat layer with a smooth trowel to close the surface and to eliminate unevenness. Total thickness of the mesh-reinforced basecoat should be 5-7 mm. When these steps are completed, the mesh lies in the first third of the basecoat. Before continuing with the next steps, allow a curing time of 1 day per mm of layer thickness.* Protect fresh basecoat from the effects of frost, rapid drying and weathering.

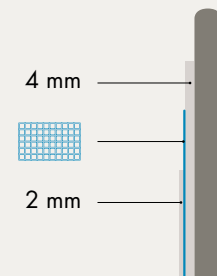

Note: With AQUAPANEL® Exterior Basecoat - white, it is best to create a layer of 4 mm thickness and using a trowel with 8 x 8 mm notches, before embedding the mesh. On top of the mesh add an extra 2 mm basecoat layer with a smooth trowel, as described in point 5.4. Allow a curing time of 1 day* for the full layer thickness and protect fresh basecoat from the effects of frost, rapid drying and weathering, before continuing with the next steps.

*All time specifications given here are depending on climate conditions.

5. Exterior Finishing

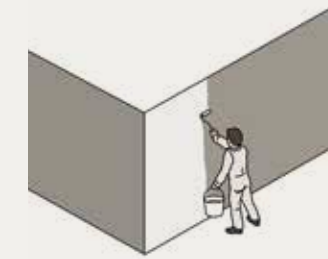

5.1 Apply AQUAPANEL® Basecoat Primer before applying the AQUAPANEL® finishing renders: AQUAPANEL® Exterior Silicon Synthetic Resin Plaster - white, AQUAPANEL® Exterior Dispersion Plaster - white, AQUAPANEL® Exterior Mineral Finish. Wait at least 24 hours before applying the finishing render, to ensure the primer is fully dried. If you want to apply paint as finishing, AQUAPANEL® Basecoat Primer is not necessary.

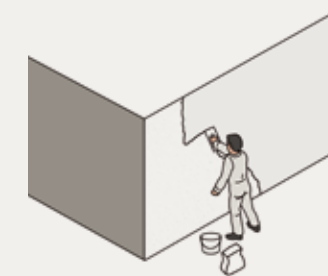

5.2 On the primed surface, finishing render is applied by hand using a trowel (use an agitator with 600 rpm to mix). Machine processing is possible when using AQUAPANEL® Exterior Mineral Finish (machine recommendation: mixing pump PFT G4, rotor/stator D4-3, half power, water requirement 200 l/h). Apply with a stainless smoothing trowel according to grain size, and then with a designated tool (foam rubber and sponge disk, PVC trowel, brush) according to the desired structure. Protect fresh render from the effects of frost, rapid drying and weathering.

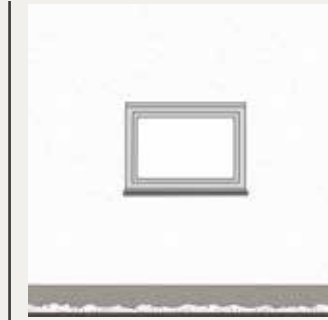
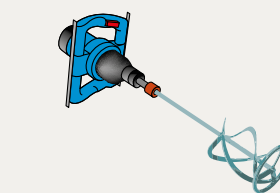

5.3 If scaffolding anchors are present, pass them through the AQUAPANEL® Cement Board Outdoor and close the remaining holes with plastic plugs when dismantling the scaffold.

Note: If you want to adhere finishing materials such as clinker bricks, glass elements or tiles, make sure to glue them in frost-free conditions using a frost-proof process. Keep the adhesive layer free from voids. Select suitable adhesives according to manufacturers' recommendations for cement bases.

For thin clinker brick and tile applications, the maximum permitted load of tiling including adhesive is 40 kg per square metre. The max. dimensions are limited to ≤ 0.12m² surface and ≤ 0.40m edge length. Contact your local Knauf staff if the load or dimensions are higher.

MATERIAL CONSUMPTION & ERECTION TIME

Product Group	Materials (from the inside to the outside)	Thickness (mm)	Weight per m ² (kg)	Material consumption per m ²	Unit	Installation time per m ² (min)
Substructure (here: 750 mm bracket spacing, 600 mm axis spacing)	Aluminium bracket (e.g. depth: 60 mm), fixing point	80.00	2.80	1	pcs.	40
	Aluminium bracket (e.g. depth: 60 mm), sliding point			2.33	pcs.	
	Anchoring means (to be provided on site)			4.33	pcs.	
	T-profile 100x50x2 mm			2	pcs.	
	Connection means (to be provided on site)			5.33	pcs.	
Exterior lining	AQUAPANEL® Cement Board Outdoor	12.50	16.00	1	m ²	15
	AQUAPANEL® Rustproofed Screw SB40	-	-	15	pcs.	
	AQUAPANEL® Joint Tape (10cm)	-	-	2.1	linear m	
	AQUAPANEL® Joint Filler - grey	-	0.70	0.7	kg	
Render (w/o finishing plaster)	AQUAPANEL® Exterior Basecoat - white	5.00	6.30	6.3	kg	10
	AQUAPANEL® Reinforcing Mesh	-	-	1.1	m ²	
Sum		97.50	25.80			65

BENEFIT FROM THE VALUABLE SERVICES FROM AQUAPANEL®



AQUAPANEL® WEBSITE

Discover a world of online resources and support available 24/7 to help you understand and communicate the full scope of the AQUAPANEL® family. Find and download in-depth technical documents, films and the latest materials, always up to date.

› www.aquapanel.com



INTERNATIONAL TRAINING CENTRE

Stay in the loop and keep your knowledge at the cutting edge with professional, practical seminars from the AQUAPANEL® International Training Centre. With courses designed to give you and your people fresh insights and understanding you get a unique advantage. For more information, please contact your local AQUAPANEL® partner or email us:

› aquapanel.info@knauf.com



YOUTUBE CHANNEL

See AQUAPANEL® in action. Our YouTube channel features product introductions and how-to videos on everything from installation to finishing options and curved wall constructions. It's all available any time – and we'll be regularly updating the channel with our latest videos, making it the first place to go for new AQUAPANEL® content.

› www.youtube.com
Search: Knauf Aquapanel

All technical changes reserved. Only the current printed instructions are valid. Our warranty is expressly limited to our products in flawless condition. The constructional and structural properties and characteristic building physics of Knauf systems can solely be ensured with the exclusive use of Knauf system components, or other products expressly recommended by Knauf. All application quantities and delivery amounts are based on empirical data that are not easily transferable to other deviating areas. All rights reserved. All amendments, reprints and photocopies, including those of excerpts, require the express permission of Knauf Aquapanel GmbH & Co. KG, Zur Helle 11, 58638 Iserlohn, Germany. AQUAPANEL® is a registered trademark.