

# WM411C.3 AQUAPANEL® Double Stud with intermediate Board

## WM411C.3-H4.1- Window exterior stud with nested KEW-profiles



Details scale 1:5

- 1) according to static calculation
- 2) observe edge clearance!

Note:

- The drawings illustrating the general concept of how the system works and interfaces with other construction components.
- The drawings do not substitute an execution design.
- Observe the static calculation, general guidelines and edge clearance.
- The technical specifications and information on the products given in the technical data sheets and system descriptions/ approvals must be observed.

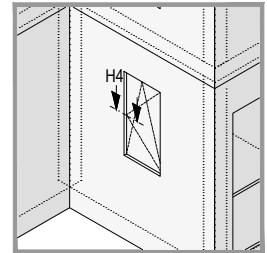

### WM411C.3-H4.1 Illustration

Outer Stud:

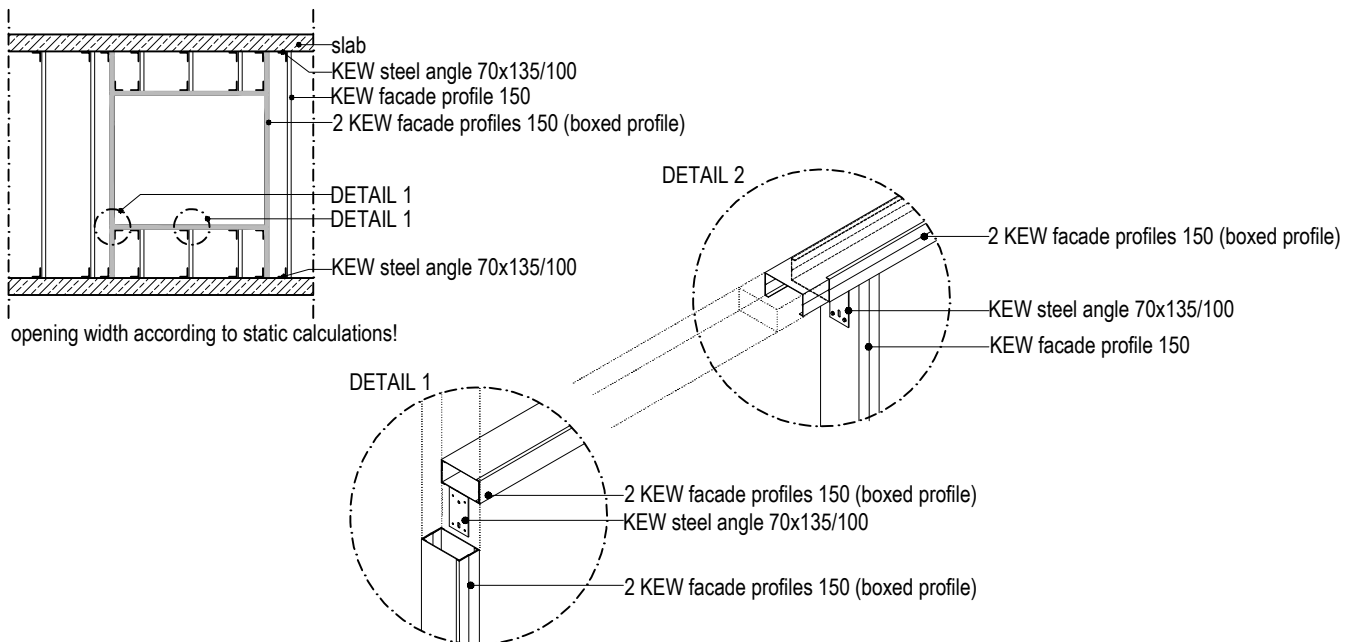

### WM411C.3-H4.1 Horizontal section

